

# EN- Operating and assembly manual

## Pipe and outlet gates

NORO Gesellschaft für Rohrsysteme mbH  
Kruppstraße 1 | 49453 Rehden | Germany  
[info@noro-rohre.de](mailto:info@noro-rohre.de) | [www.noro-rohre.de](http://www.noro-rohre.de)

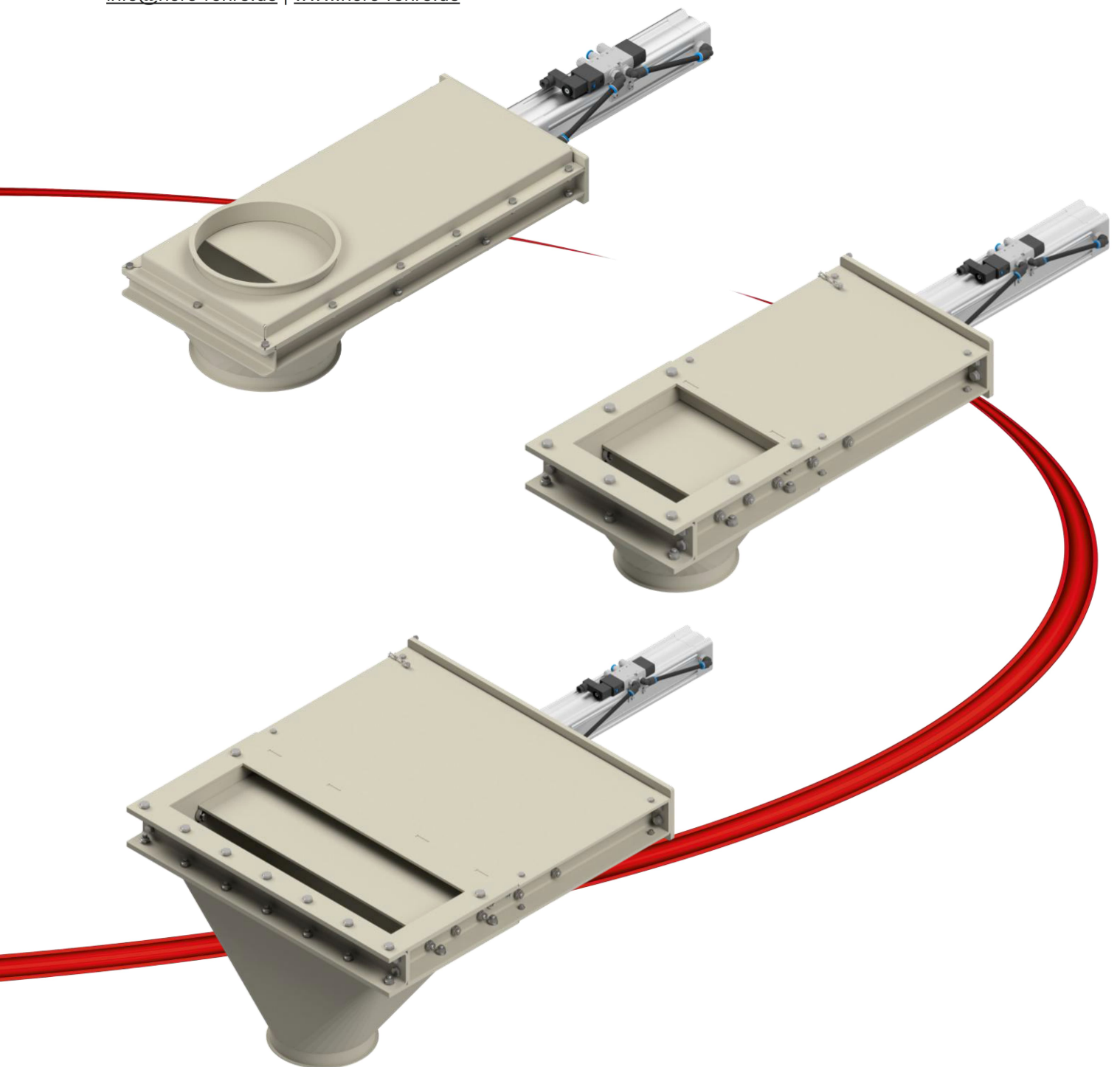

## Foreword

We are delighted that you have purchased our product and thank you for the trust you have placed in our company.

This operating and assembly manual contains all the necessary information required for the proper use, safe assembly of the pipe and outlet gates described below, connection, commissioning, handling, maintenance and servicing.

This product is an incomplete machine within the meaning of the Machinery Directive 2006/42/EC and is not capable of functional independently. The pipe and outlet gates may only be put into operation once it has been established that the complete unit into which they are to be installed complies with the applicable provisions of the Machinery Directive and the declaration of conformity for the complete machine is available.

The pipe and outlet gates have been developed and manufactured in accordance with the relevant harmonized standards. Nevertheless, improper installation or improper use can pose a risk to people, property and the environment.

Therefore, read these instructions carefully before you start the assembly of, or connection or integration of, the incomplete machine. Follow the instructions described for all steps.

# Table of contents

<b>Foreword</b>	<b>2</b>
<b>Table of contents</b>	<b>3</b>
<b>1 General information</b>	<b>5</b>
1.1 Purpose of the manual	5
1.2 Applicable documents	5
1.3 Notes to the operator	6
1.4 Meaning of symbols and warnings	7
<b>2 Safety</b>	<b>8</b>
2.1 Intended use	8
2.2 Foreseeable misuse	9
2.3 General safety instructions	10
2.4 Sources of danger and residual risks	10
2.5 Protective measures and protective equipment	11
2.6 Personal protective equipment (PPE)	12
2.7 Qualification and training of staff	13
2.8 Safety during assembly, operation, maintenance and disassembly	15
<b>3 Technical descriptions</b>	<b>16</b>
3.1 Pipe gate	16
3.1.1 Product structure	17
3.1.2 Product description	18
3.2 Silo outlet gate	19
3.2.1 Product structure	20
3.2.2 Product description	21
3.3 Redler outlet gate	22
3.3.1 Product structure	23
3.3.2 Product descriptions	24
3.4 Technical data	25
3.5 Nameplate	25
<b>4 Transport and storage</b>	<b>26</b>
4.1 Transport	26
4.2 Storage	26
<b>5 Assembly</b>	<b>28</b>

5.1	Preparatory measures	28
5.2	Mounting position	29
5.3	Integration into the pipeline	30
5.3.1	Clamping ring connections: Clamping rings with sealing rings	30
5.3.2	Flange connection: loose flange	31
5.3.3	Flange connection: fixed flange	33
<b>6</b>	<b>Commissioning</b>	<b>34</b>
6.1	Connection of the electrical and pneumatic components	34
<b>7</b>	<b>Use in potentially explosive environments</b>	<b>35</b>
7.1	Conditions of use	35
7.2	Equipotential bonding	36
7.3	Avoidance of ignition sources	37
<b>8</b>	<b>Operational disruptions</b>	<b>38</b>
<b>9</b>	<b>Maintenance and inspection</b>	<b>39</b>
9.1	Maintenance plan	39
9.2	Inspection requirements	39
9.3	Replacement of spare parts	40
9.3.1	Replacement of the seal for pipe gates	40
9.3.2	Replacement of the seal for outlet gates	42
9.3.3	Replacement of a pneumatic lifting cylinder	44
9.3.4	Replacement of an electric linear actuator	45
9.4	Cleaning instructions	46
<b>10</b>	<b>Disassembly and disposal</b>	<b>47</b>
10.1	Disassembly	47
10.2	Disposal	47

# 1 General information

## 1.1 Purpose of the manual

The compliance with the operating manual is a prerequisite for trouble-free operation and the fulfilment of warranty claims.

Therefore, please read the operating and assembly manual first before using the pipe and outlet gates. The manual contains important information about servicing. Therefore, keep them in your records.

Please observe the instructions in the individual chapters of the operating and assembly manual.



## 1.2 Applicable documents

In addition to this operating and assembly manual, the complete documentation package includes the following documents, depending on the respective version:

- Technical data sheet
- EC declaration of incorporation in accordance with the EC Machinery Directive 2006/42/EC, Annex II, B for incomplete machinery
- Acceptance report
- Documentation for pneumatic or electrical components
- ATEX declaration of conformity in accordance with EC Directive 2014/34/EU (only for ATEX version)

### 1.3 Notes to the operator

The operator is obliged to read this operating and assembly manual carefully before using the pipe and outlet gates and to ensure that all persons involved – including planners, fitters, operators and maintenance personnel – understand and apply its contents.

The operator can integrate the manual into the manual of the complete machine or the entire system. The instructions must be easily accessible at the place of use and consulted in case of uncertainty or doubt.

The intended use of the gates must be observed (*see, p.8, 2.1 Intended use*). The manufacturer shall not be liable for damage or malfunctions resulting from failure to comply with these operating and installation instructions. The risk is borne solely by the operator, and warranty claims shall lapse in the event of non-compliance.

The operator is responsible for carrying out a comprehensive hazard assessment of the entire system in which this component is integrated and must take potential residual risks into account. Based on this assessment, additional protective measures may need to be implemented. The operator is responsible for the conformity of the entire system, including the CE marking.

The operator must ensure that no unauthorised modifications, additions or alterations are made to the gate, as these may compromise safety, functionality and reliability. We recommend using only original spare parts and accessories authorised by the manufacturer to ensure technical requirements and safety are met.

The operator is responsible for compliance with the ATEX directive throughout the entire system, where necessary.

These notes are intended to assist the operator in fulfilling their duty of care, ensuring the safety of personnel and the system, and comprehensively considering the requirements of the Machinery Directive 2006/42/EC.

## 1.4 Meaning of symbols and warnings

The safety and hazard instructions listed in this operating and assembly manual are intended to protect you, third parties and the protection of the product. The instructions must be followed.



### DANGER

Dangerous situation that can result in death or serious injury if not observed.



### WARNING

Potentially dangerous situation that can result in death or serious injury if not observed.



### CAUTION

Potentially dangerous situation that can result in minor to moderate injury if not observed.



### NOTE

Important information and notes.

## 2 Safety

The safety of the gate is guaranteed according to the state of the art, but there are residual risks that must be minimized by appropriate measures. The operator is obliged to implement the following safety aspects to prevent personal injury and damage to property and to comply with the requirements of the Machinery Directive 2006/42/EC.

### 2.1 Intended use

The pipe and outlet gates are intended exclusively for shutting off granular or powdery bulk materials in non-pressurized, vertical pipelines ("free fall"). The residual moisture of the bulk material must not exceed 15%.

In ATEX versions, use is limited to bulk materials with a KSt value of up to 160 bar m/sec.

Operational safety is only guaranteed if the gate is used in an enclosed space and all connections in the system are professionally installed, tension-free and sealed. Outdoor use is only possible with an appropriate protective coating and suitable protective covers.

The permissible operating limits in terms of pressure, temperature and flow rate must be observed to ensure proper functioning. These depend on the sealing materials used, the attachments and the applicable technical data. The operating limits can be found in the applicable technical data sheet. A further prerequisite for intended use is that the gate is operated exclusively with the components and accessories authorised by the manufacturer.

## 2.2 Foreseeable misuse

Any deviation from the intended use constitutes misuse.

In particular, the following cases are considered foreseeable misuse:

- Operation of the gate without connected pipelines or without the prescribed clamping ring or flange connection, which can result in significant crushing hazards.
- Removing, bypassing or manipulating protective devices as well as operating with overridden safety devices.
- Use of the gate with liquids and gases, adhesive or aggressive media, explosive or self-igniting substances, as well as operation outside the permissible pressure and temperature ranges.
- Use in conveyor systems for seeds
- Use in pneumatic conveyor lines with positive or negative pressure
- Installation in inclined pipelines.
- Stepping on the gate or adjacent pipelines
- Exceeding the maximum permitted switching frequency (>100 switches/hour).
- Removal or manipulation of valve throttles in pneumatically driven components.
- Carrying out maintenance or repair work while the system is under pressure or tension, or without interrupting the product flow, as well as leaving tools or foreign objects in the case.
- Operation in potentially explosive areas without appropriate ATEX certification or without grounding against electrostatic charge.

The aforementioned misuse can lead to significant personal injury and property damage. The manufacturer accepts no liability for damage caused by improper use. The risk is borne solely by the operator.

## 2.3 General safety instructions

The operating instructions must be read in full before the assembly of the product, commissioning, operation, maintenance or disassembly and must be always kept available. All national and company regulations on accident prevention and environmental protection must be observed. Operation of the gate is permitted only in perfect condition, and regular inspections are required. In the event of malfunctions, such as failure to switch or leaks, the system must be shut down immediately. Proper grounding must be ensured in potentially explosive atmospheres and only ATEX-compliant designs may be used, whereby conductive media must be excluded, and temperature classes must be observed. Environmental pollution from lubricants or cleaning agents should be avoided, and energy consumption (e.g. compressed air) should be optimised to promote sustainability.

## 2.4 Sources of danger and residual risks

The gate harbours various sources of danger that cannot be eliminated by design. Mechanical hazards include crushing and shearing from the movable inner slider plate or drive, injuries caused by sharp edges due to wear, leakage of bulk materials under pressure, and blockages or overloads caused by product columns. Electrical hazards exist in the form of electric shocks or short circuits when working on electric drives, solenoid valves or limit switches. Mechanical hazards (e.g. when using pneumatics) include injuries caused by compressed air escaping or explosion hazards in the event of overpressure. Thermal hazards arise from hot surfaces that can cause burns. Chemical/biological hazards result from harmful materials or lubricants (skin/eye irritation, infections). Acoustic hazards caused by noise >85 dB(A) can cause hearing damage. In ATEX areas, there are explosion risks due to electrostatic charges, sparks or overheating, which must be minimised by grounding and suitable designs. Additional common hazards include changes in switching speed, power supply or control failure, incorrect assembly of components or breakage during operation.

The operator must take these residual risks into account in the hazard assessment for the entire system.

## 2.5 Protective measures and protective equipment

Specific protective measures are needed to minimise the risks. Protective devices such as covers or limit switches must not be removed or bypassed. Installation in a pipe system prevents direct access to the movable slider plate and reduces the risk of crushing or shearing.

An emergency stop system in accordance with EN ISO 13850 should be integrated into the entire system. Before maintenance work, the power and compressed air supply must be disconnected and secured against being switched back on to prevent hazards.

In ATEX areas, ignitable conditions (e.g. sparks, rapid movements exceeding 1m/s) must be avoided and the temperature classes of the attachments must be observed. Proper grounding or equipotential bonding prevents electrostatic charges in ATEX areas. The operator must implement additional protective measures based on their hazard assessment.

## 2.6 Personal protective equipment (PPE)

The use of personal protective equipment (PPE) is required to ensure the safety and health of employees in the workplace.

The operator shall ensure that the necessary PPE is provided, regularly inspected and maintained. Operating personnel are responsible for the proper use of PPE.

Before commencing the relevant activities related to this product, at least the following personal protective equipment must be provided:



### **Use foot protection!**

Wear suitable foot protection during transport, assembly of, disassembly, maintenance and cleaning work.



### **Use hand protection!**

Wear suitable hand protection during transport, assembly of, disassembly, maintenance and cleaning work.



### **If necessary: use head protection!**

Wear suitable head protection when working overhead, e.g. when lifting, during the assembly of equipment or during maintenance work.



### **If necessary: use hearing protection!**

Wear suitable hearing protection when noise levels exceed 85 dB (A).



### **If necessary: use protective clothing!**

Wear suitable protective clothing when carrying out maintenance and cleaning work.

## 2.7 Qualification and training of staff

The individual activities at the gate require different personnel qualifications, which are listed in the table "Qualification matrix" (*see p. 14, table "Qualification matrix"*).

The contents of the operating and assembly instructions must be fully understood by the personnel. If necessary, the required knowledge should be imparted through training courses. If desired, this can be carried out by the manufacturer on behalf of the operator.

Responsibilities for operation, maintenance and troubleshooting must be clearly defined and documented to ensure safe and efficient handling. Young people may only work under the supervision of a qualified professional. The different qualifications are characterised by the following skills and knowledge:

- **Planners/operators** have knowledge of pipe system design, hazard assessment, ATEX and hygiene regulations where applicable and are responsible for the conformity of the entire system, training, documentation and environmental protection.
- **Trained persons/operating personnel** are familiar with safety regulations, PPE use and simple operating tasks and are responsible for safe system monitoring and reporting any abnormalities.
- **Specialists** possess technical knowledge in mechanics and pneumatics, carry out the assembly of components, maintenance and troubleshooting, and are responsible for compliance with safety and hygiene regulations
- **Electricians** are responsible for installing, maintaining and repairing electrical components and are responsible for laying cables to connect to control and switch cabinets.

The table should be interpreted as follows:

**"A specialist is required to assemble the gate."**

Activities	Planners / Operators	Trained persons / operating personnel	Specialist	Electrician
Planning and technical design	X			
Transport		X		
Assembly			X	
Pneumatic installation			X	
Installation, maintenance and disassembly of electrical components				X
Commissioning			X	
Operation		X		
Maintenance, servicing & cleaning			X	
Troubleshooting & fault rectification			X	
Disassembly			X	
Disposal & recycling	X		X	

Table: "Qualification matrix "

## 2.8 Safety during assembly, operation, maintenance and disassembly



### NOTE

- Work on the gate may only be carried out during a standstill.
- Clean the inside of the pipe or outlet gate before working on it

The following steps must be carried out to shut down the gate:

- Interrupt product feed to the gate
- Switch off the compressed air supply to the pneumatic system
- Switch off the main switch
- Secure main switch to prevent reactivation



### DANGER

- Do not switch the gate back on immediately if it has stopped for reasons that are initially unexplained. Someone may have stopped the system for manual intervention and failed to secure it against reactivation. Unexpected reactivation may result in injury (personal injury).
- When carrying out maintenance work inside the gate, all connection openings should be securely covered to prevent injuries and to prevent objects from falling into the pipelines.
- Protective devices must not be modified, removed or impaired in their function.



### WARNING

- For safety reasons, original spare parts and accessories authorized by the manufacturer must be used for repairs. The use of other parts may result in personal injury and property damage.
- Modifications or alterations to the gate are only permitted after consultation with the manufacturer. All correspondence regarding this matter must be conducted in writing



### NOTE

- The electrical control of the gate is carried out by the system operator.

### 3 Technical descriptions

#### 3.1 Pipe gate

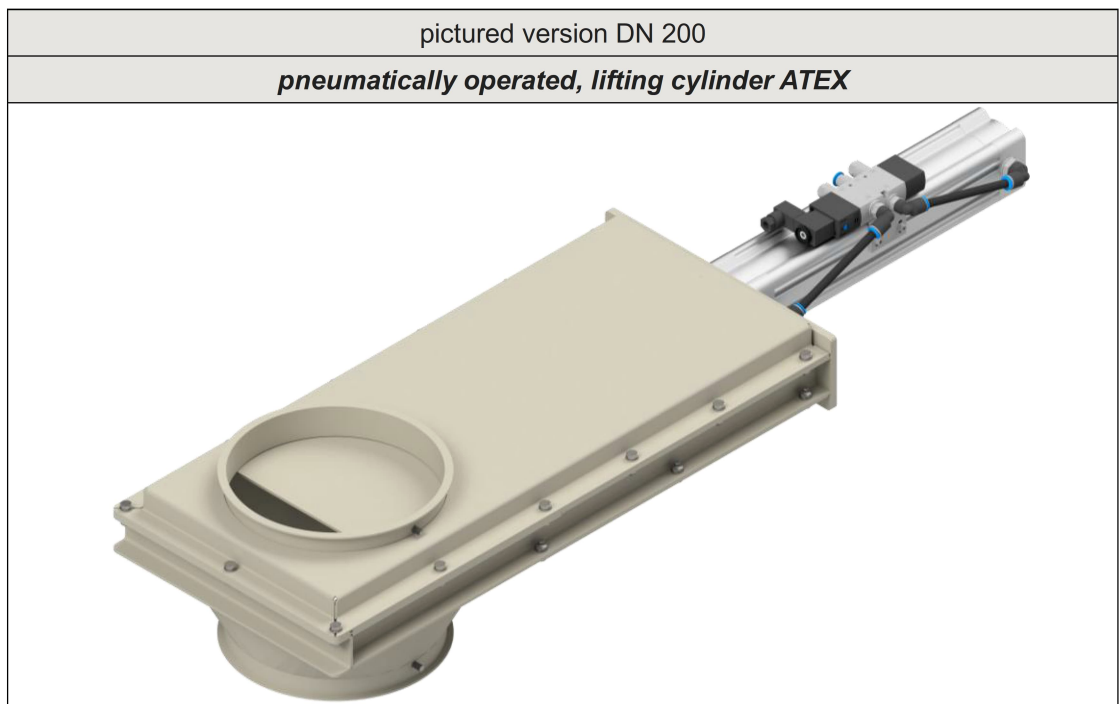
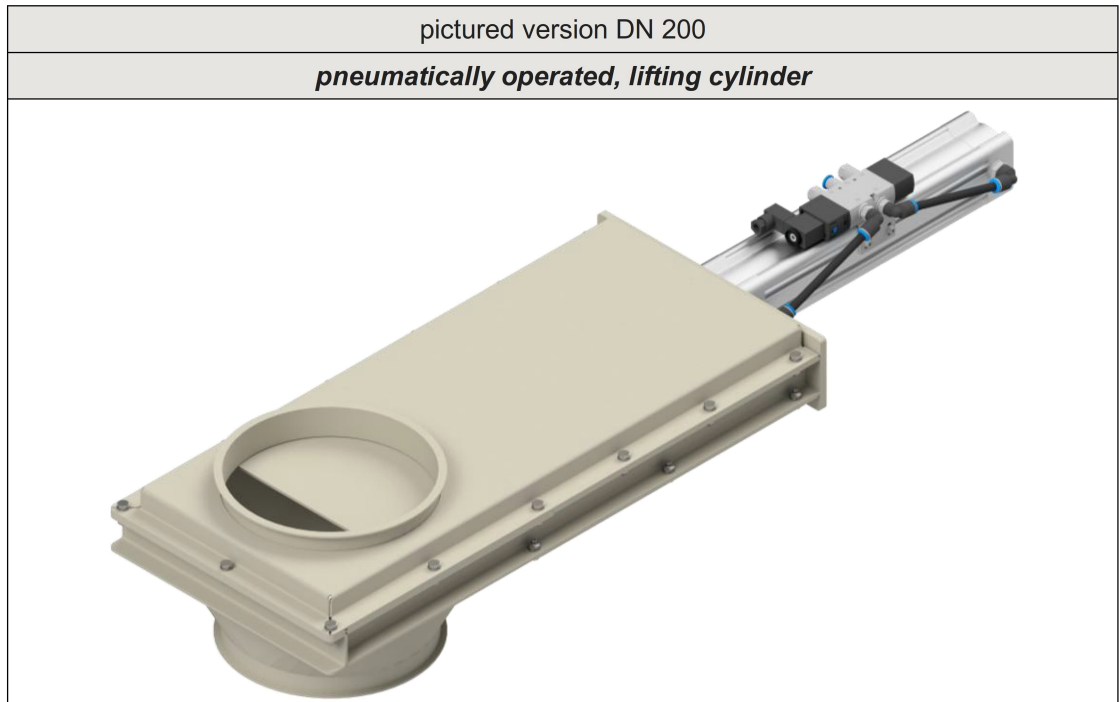

3.1.1 Product structure

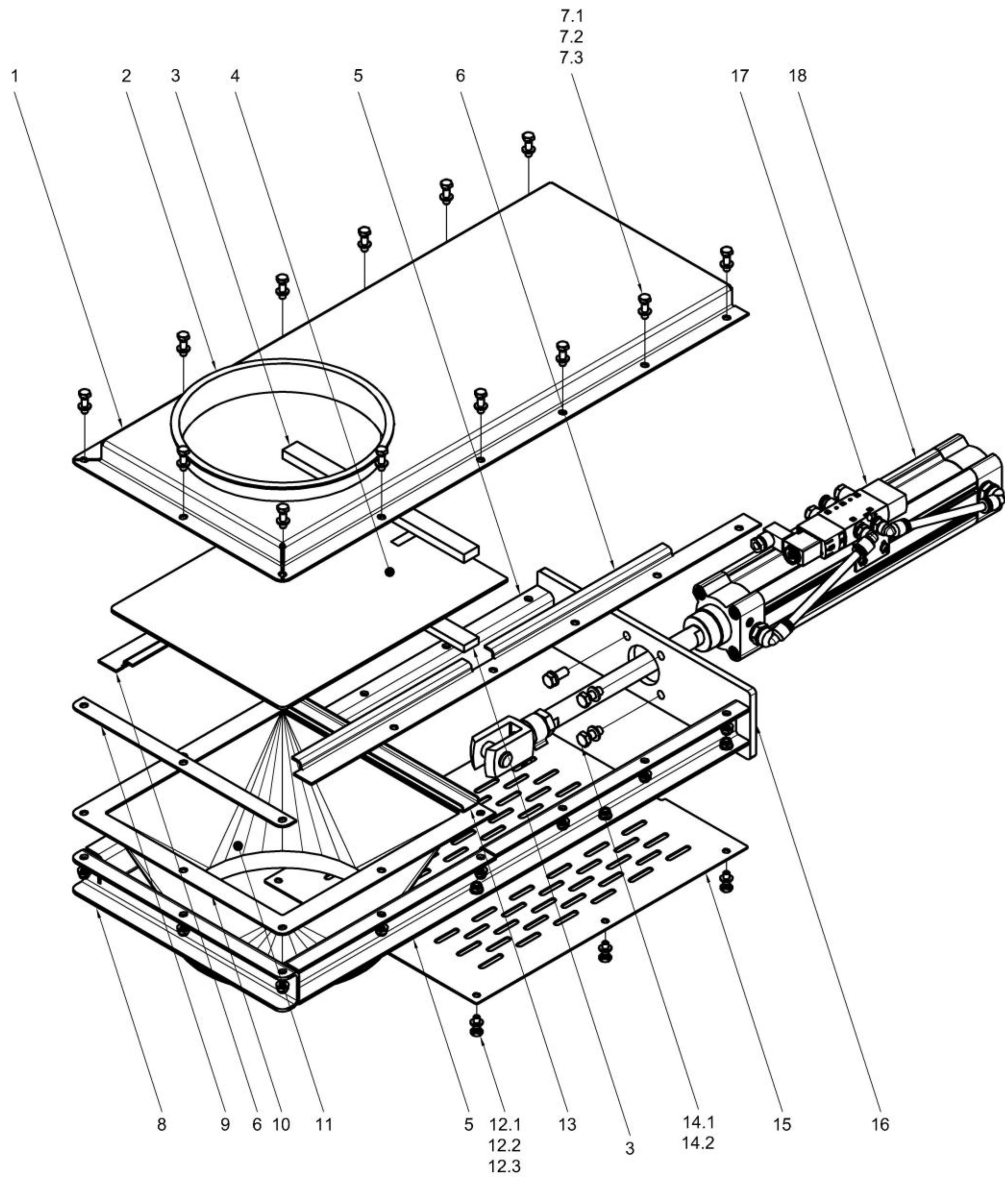

No.	Naming	Quantity	No.	Naming	Quantity
1	Top	1	10	Square flange	1
2	Inlet	1	11	Outlet transition piece	1
3	Sealing strips	2	12	Screw connection	variable
4	Slider plate	1	13	U-rail	2
5	U-frame (on the side)	2	14	Screw connection	variable
6	Guide rail	2	15	Protective cover	1
7	Screw connection	variable	16	Cylinder mount	1
8	U-frame (front)	1	17	Solenoid valve	1
9	Compensating rail	1	18	Lifting cylinder	1

### 3.1.2 Product description

The medium runs in free fall over the inlet (2) into the pipe gate. The flow is either shut off or released by the slider plate (4). The downstream pipeline is connected via the outlet transition piece (11).

The slider plate runs in the case on two side-mounted guide rails (6) and is linearly adjusted to the desired position via a lifting cylinder (18). Two sealing strips (3) provide a seal to the rear case part.

The lifting cylinder is attached to the cylinder mount (16) and is controlled by the customer via the solenoid valve (17).

The slotted protective cover (15) enables optical slide position detection.

### 3.2 Silo outlet gate

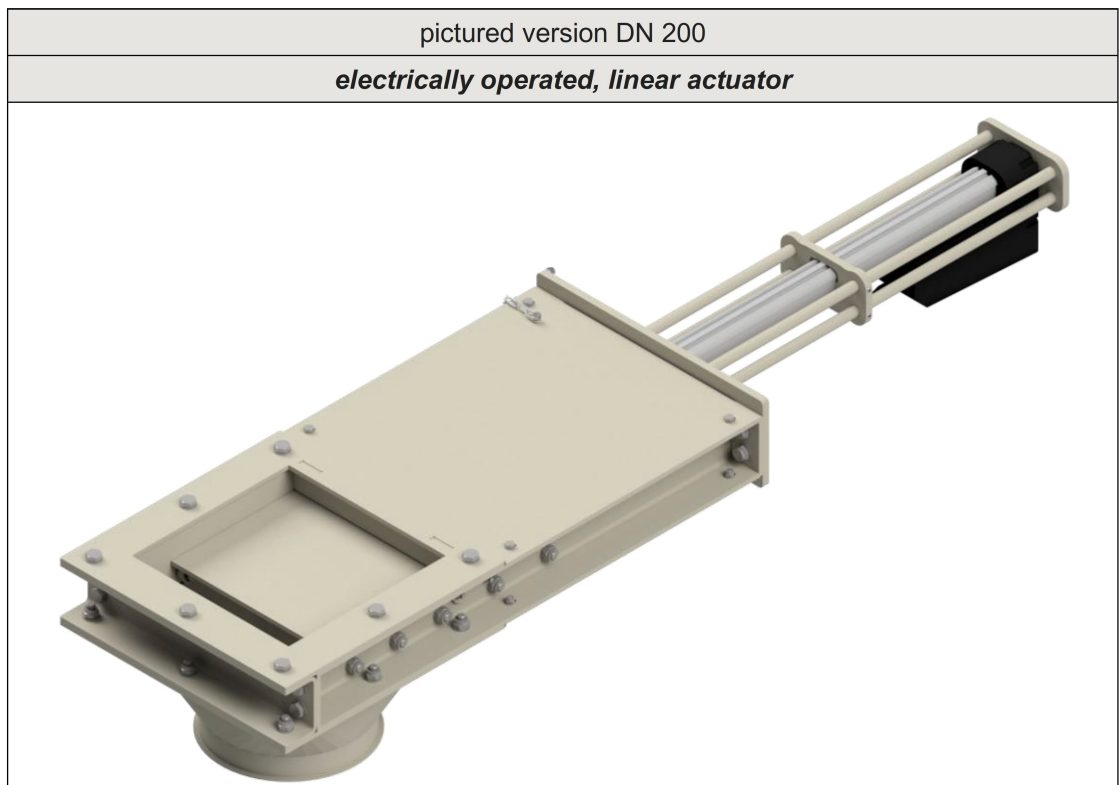
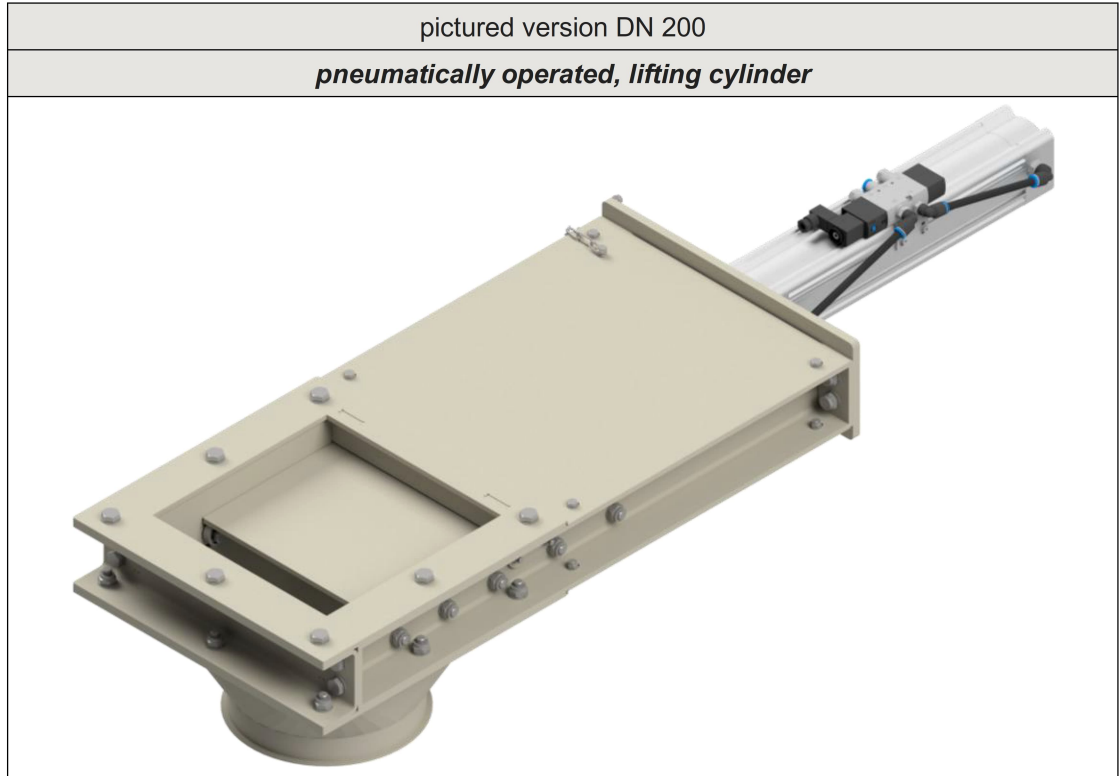

### 3.2.1 Product structure

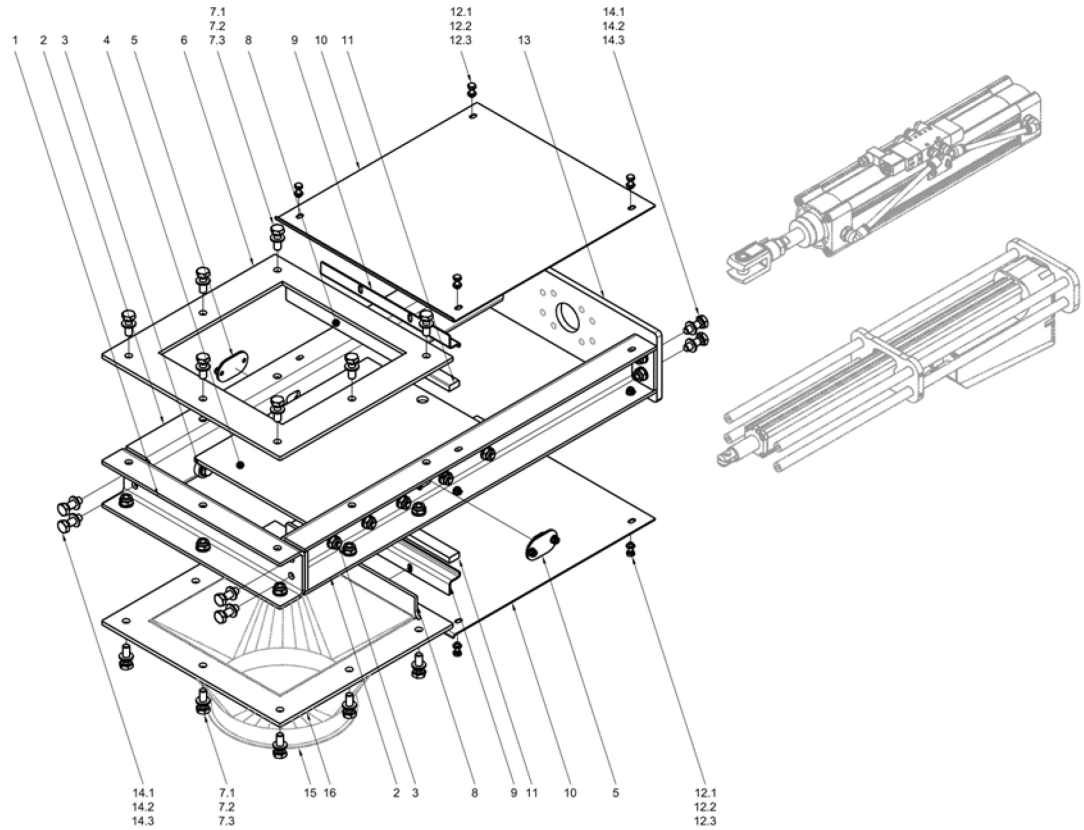

No.	Naming	Quantity	No.	Naming	Quantity
1	U-frame (front)	1	9	Sealing plate	2
2	U-frame (on the side)	2	10	Protective cover	2
3	Guide bearings	variable	11	Sealing strips	2
4	Slider plate	1	12	Screw connection	variable
5	Inspection opening	2	13	Drive mount	1
6	Inlet flange	1	14	Screw connection	variable
7	Screw connection	variable	15*	Outlet transition piece*	1
8	Sealing plate holder	2	16	Outlet flange	1

*\*only version "with transition piece"*

### 3.2.2 Product description

The inlet flange (6) is connected to the customer's inlet transition piece.

The medium runs in free fall through the opening of the inlet flange into the case. The flow is either shut off or released by the slider plate (4). The downstream pipeline is connected via the outlet transition piece (15) or outlet flange (16).

The slider plate (4) runs in the case on several laterally mounted guide bearings (3) and is linearly set to the desired position via a drive (lifting cylinder/linear actuator). Two sealing strips (11) provide a seal to the rear case part. Two inspection openings (5) on the sides allow visual wear control of the sealing strips. The sealing effect of the sealing strips on the slider plate can be subsequently increased by means of one sealing plate (9) each.

The drive is attached to the drive mount (13) and controlled by the customer.

### 3.3 Redler outlet gate

pictured version DN 200

*pneumatically operated, lifting cylinder*

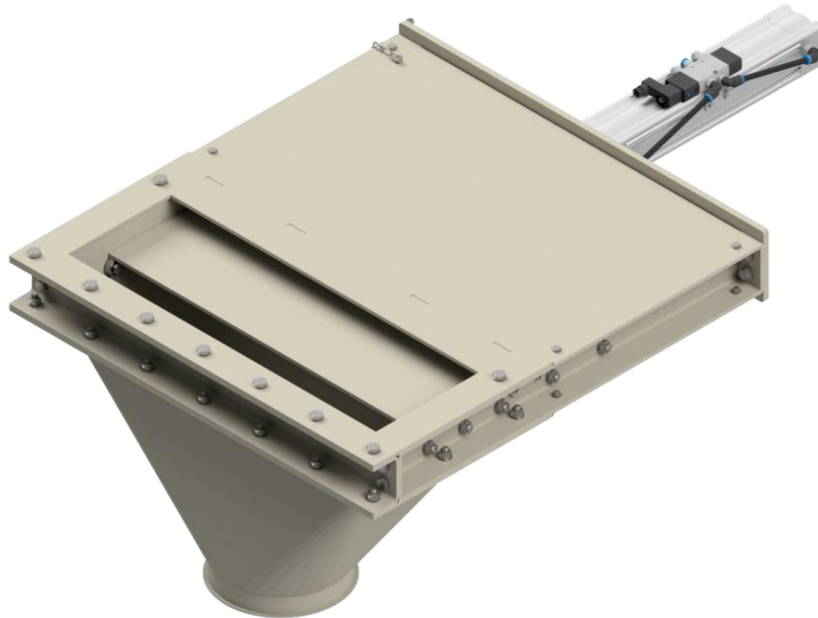

pictured version DN 200

*electrically operated, linear actuator*

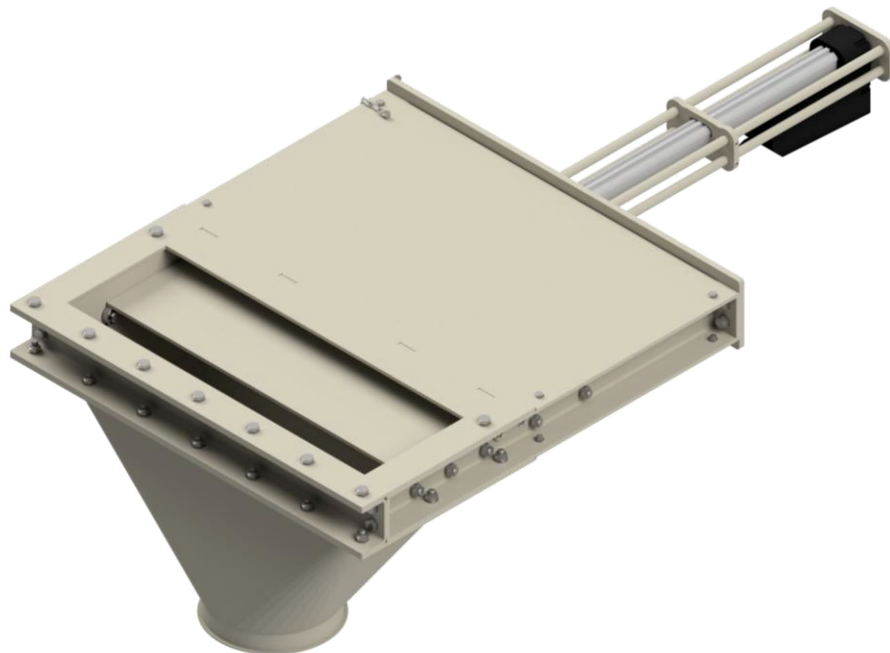

3.3.1 Product structure

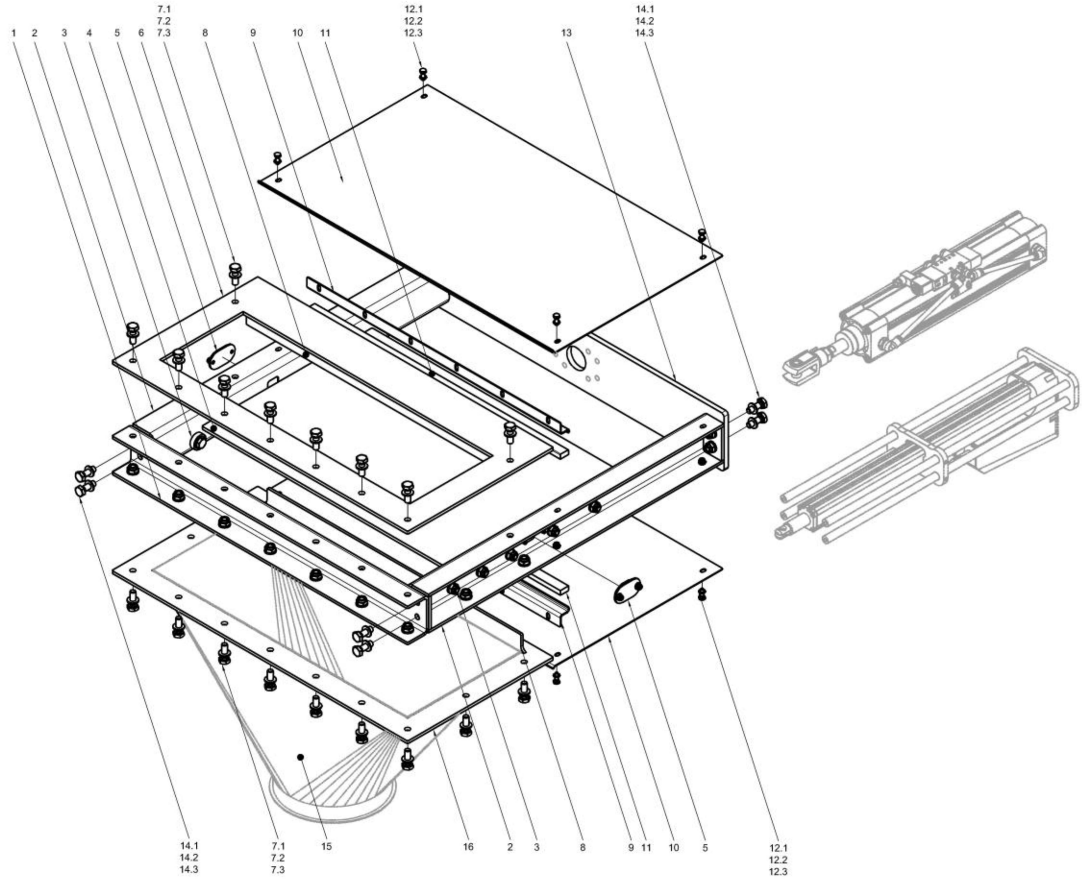

No.	Naming	Quantity	No.	Naming	Quantity
1	U-frame (front)	1	9	Sealing plate	2
2	U-frame (on the side)	2	10	Protective cover	2
3	Guide bearings	variable	11	Sealing strips	2
4	Slider plate	1	12	Screw connection	variable
5	Inspection opening	2	13	Drive mount	1
6	Inlet flange	1	14	Screw connection	variable
7	Screw connection	variable	15	Outlet transition piece*	1
8	Sealing plate Holder	2	16	Outlet flange	1

\*only version "with transition piece"

### 3.3.2 Product descriptions

The inlet flange (6) is connected to the customer's inlet transition piece.

The medium runs in free fall through the opening of the inlet flange into the case. The flow is either shut off or released by the slider plate (4). The downstream pipeline is connected via the outlet transition piece (15) or outlet flange (16).

The slider plate (4) runs in the case on several laterally mounted guide bearings (3) and is linearly set to the desired position via a drive (lifting cylinder/linear actuator). Two sealing strips (11) provide a seal to the rear case part. Two inspection openings (5) on the sides allow visual wear control of the sealing strips. The sealing effect of the sealing strips on the slider plate can be subsequently increased by means of one sealing plate (9) each.

The drive is attached to the drive mount (13) and controlled by the customer.

### 3.4 Technical data

See applicable technical data sheet.

### 3.5 Nameplate



1	Name and address of the manufacturer
2	Article number; if applicable, ATEX marking
3	Serial number
4	QR code with reference to website
5	Calendar week/year of construction

## 4 Transport and storage

### 4.1 Transport

Inspect the delivery immediately upon receipt for any transport damages. Communicate this immediately to the manufacturer or the transport company. You may not be able to operate a damaged gate. Depending on the number of items, the gate is delivered horizontally loose or in a packaging box. In-house transport to storage or final assembly can be done by forklift, pallet truck or manually.

### 4.2 Storage

In case of long-term storage, please check whether the case shows any kind of damage and that all moving parts fulfil their functions. For long-term storage, please observe the storage conditions listed in the following table:

<b>Climate zone: moderate</b> (Europe, USA, Canada, China and Russia, except for tropical areas)		
Packaging*	Packed in containers, sealed in foil with desiccant and humidity indicator	Open (no packaging)
Storage location	Covered, protection against rain and snow, vibration-free	Covered and closed at a constant temperature and humidity (5 °C to 60 °C, < 50% relative humidity). No sudden temperature changes, no aggressive vapours and no vibrations.
Storage period	Max. 3 years with regular inspection of packaging and humidity indicator (relative humidity < 50%)	2 years and more with regular inspection. Check for cleanliness and mechanical damage during inspection. Check the integrity of the anti -corrosion coating.

<b>Climate zone: tropical</b> (Asia, Africa, Central and South America, Australia, New Zealand, excluding temperate areas)		
<b>Packaging*</b>	<b>Packed in containers, sealed in foil with desiccant and humidity indicator</b>	<b>Open (no packaging)</b>
<b>Storage location</b>	Covered, protection against rain and snow, vibration-free	Covered and closed at a constant temperature and humidity (5 °C to 60 °C, < 50% relative humidity). No sudden temperature fluctuations, no aggressive vapours and no vibrations, protection from insect damage.
<b>Storage period</b>	Max. 3 years with regular inspection of packaging and humidity indicator (relative humidity < 50%)	2 years and more with regular inspection. Check for cleanliness and mechanical damage during inspection. Check the integrity of the anti -corrosion coating.

**i NOTE**

The packaging must be performed by an experienced company using packaging material expressly approved for the application.

## 5 Assembly

### 5.1 Preparatory measures

Pipe and outlet gates are designed for installation in a pipeline and for assembly with other machines.

During installation, ensure that there are sufficient suspension and support. For the component dimensions and weights, please refer to the applicable technical data sheet.

The further pipe construction must be assembled and suspended without tension.

Outdoor installation is only possible if the gates are coated with a weatherproof protective coating. For gates with electric and/or pneumatic actuators, additional protective covers may be required. The actuators must be designed for the ambient temperatures.

The end positions of the gates are preset at the factory via the limit switches or proximity switches. If necessary, adjust the gates end positions using the limit switches. The procedure for adjusting the end position can be found in the manufacturer's documentation.



#### NOTE

In the case of **silos and redler outlet gates**, the connection is made via a connection flange on the customer's side (shown in red). The connection dimensions can be found in the corresponding data sheet.

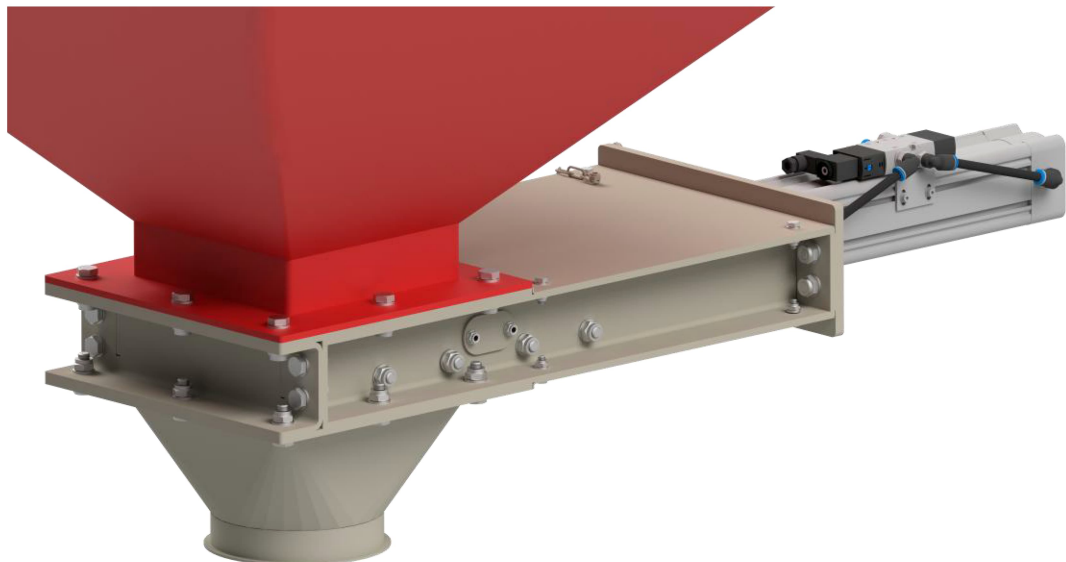

## 5.2 Mounting position

Conveying must only take place in free fall, so that the gate must be installed vertically. Any inclined position is considered an incorrect application and can affect both the function and service life of the gate.

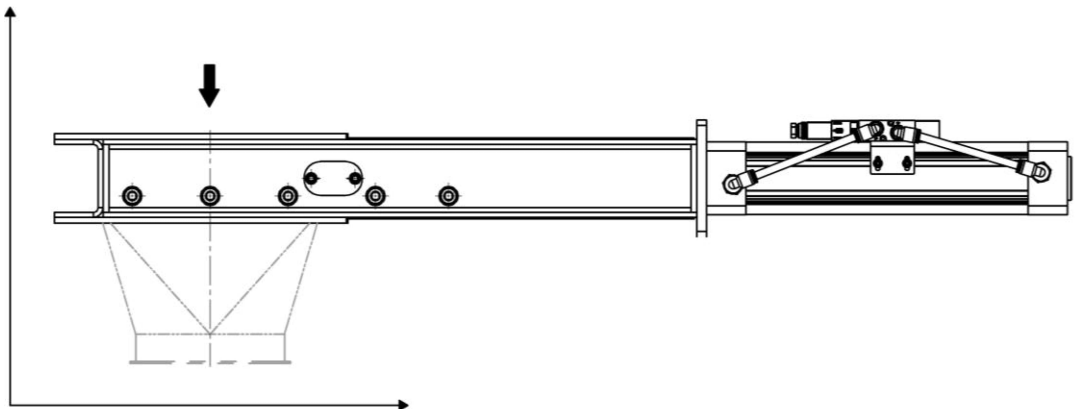
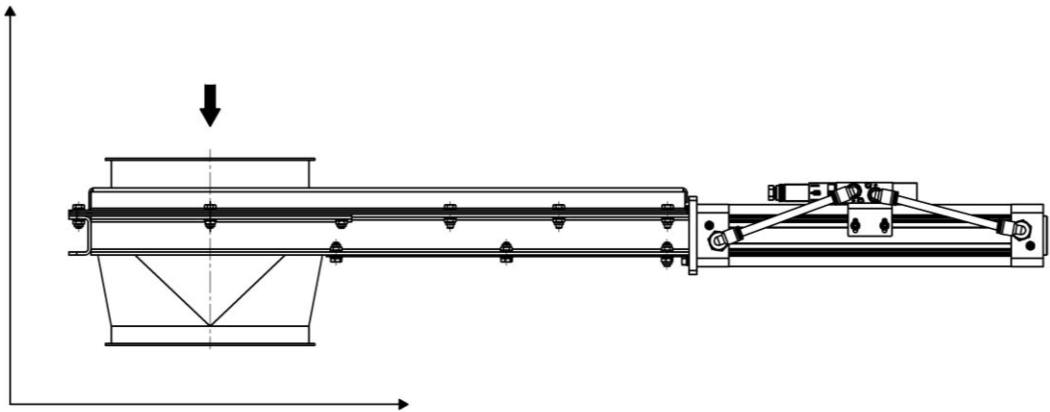

## 5.3 Integration into the pipeline

The gate can be assembled with the pipeline via clamping ring connections or flange connections.

### 5.3.1 Clamping ring connections: Clamping rings with sealing rings



#### NOTE

Select clamping and sealing rings to match the pipe diameter and material thickness.

1



Pull the sealing ring - starting from the seam - over one of the flanged edges (lips). The profiled side of the sealing ring must point towards the connection pipe part. The sealing ring can be easily expanded for mounting.

2



Now place the connection pipe to fit the pipe with the tightly wound sealing ring.

3



Loosen both tension screws of the clamping ring, but do not unscrew them completely from the tie rods. One of the tie rods is yellow galvanized or has a groove. Unhook this tie rod and open the tension ring.



Now place the clamping ring around the two joined pipe parts and hook the tie rod back in.



Finally, tighten the two screws evenly with a screwdriver/torque wrench.

### 5.3.2 Flange connection: loose flange

*flanges lose behind flanged edges (lips)*

**i** **NOTE**

For loose flange connections, use sealing rings (DN 80 – DN 300) or sealing rings for 10 mm flanged edges (*lips*) (DN 350 – DN 710).

- 1 Loosen the transport locks on the flange and push the flange back slightly from the flanged edge.



Pull the sealing ring - starting from the seam - over one of the lips. The profiled side of the sealing ring must point towards the connection pipe part. The sealing ring can be slightly expanded for winding.



Now place the connection pipe to fit the pipe with the tightly wound sealing ring and pull the flange to the sealing ring.

4 Align the flanges of the two pipe parts to be connected so that the holes are over each other.



For each screw connection, a washer must be placed on the screw, the screw must be passed through both flanges, then another washer must be placed, and the nut must be screwed together by hand.

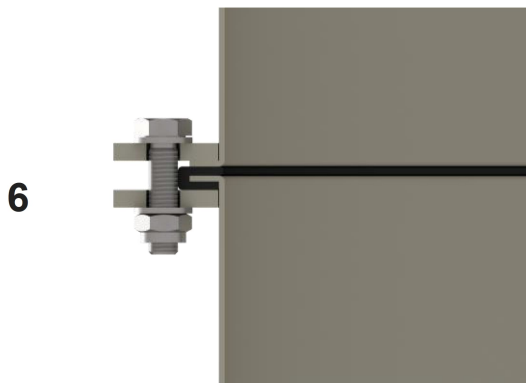

Then use the torque wrench to tighten two opposing screw connections at a time. The remaining screws are then tightened in any order.

The following tightening torques must be observed:

M10 → 40 Nm

M12 → 60 Nm

M16 → 80 Nm

**NOTE**

In the case of split flanges, the flanges must be mounted offset.

### 5.3.3 Flange connection: fixed flange

welded flanges



#### NOTE

For fixed flange connections, use flat seals that you place between the flanges

- 1 Align the flanges of the pipe parts to be connected so that the holes are over each other.

2



For each screw connection, a washer must be placed on the screw, the screw must be passed through both flanges, then another washer must be placed, and the nut must be screwed in hand.

3



Then use the torque wrench to tighten two opposing screw connections at a time. The remaining screws are then tightened in any order.

The following tightening torques must be observed:

M10	→	40 Nm
M12	→	60 Nm
M16	→	80 Nm

## 6 Commissioning

### 6.1 Connection of the electrical and pneumatic components

Before commissioning, a control system must be available or procured for components with electrical and/or pneumatic actuations. All necessary control cables must be connected according to the terminal diagram. The terminal diagrams for drives and drive components can be found in the corresponding data sheets and instructions of the manufacturers. The clamping diagrams and circuit diagrams for the control system must be provided on site by the system operator.

For pneumatically operated gates, ensure sufficient operating pressure (at least 5 bar).

For electrically actuated components, make sure that there is a sufficient/suitable operating voltage.

After installation and electrical connection, a test run with a function check must be carried out.

## 7 Use in potentially explosive environments

### 7.1 Conditions of use

Pipe and outlet gates are marked accordingly for use in hazardous areas for Zone 22 (dust) (*see p.25, 3.4 Nameplate*). They are suitable for use in low-dust environments where an explosive atmosphere is rare and short-lived in normal operation.

## 7.2 Equipotential bonding

Pipe and outlet gates are equipped with factory-welded grounding bolts (M6 x 10 mm) for use in potentially explosive areas to safely dissipate electrostatic charges.

During installation, it must be ensured that the gate is conductively connected to the connected pipeline and the equipotential bonding system of the entire system via suitable grounding cables. The electrical connection must be durable and corrosion resistant. The applicable regulations must be observed. Before commissioning, the grounding resistance according to VDE 0165 ( $< 10^6$  ohms) must be tested and verified by a phase resistance measurement.

The operator is obliged to regularly check the proper equipotential bonding and to document the results. Improperly executed or interrupted grounding can lead to the formation of ignition sources due to electrostatic discharges and represents a considerable risk in the potentially explosive area.

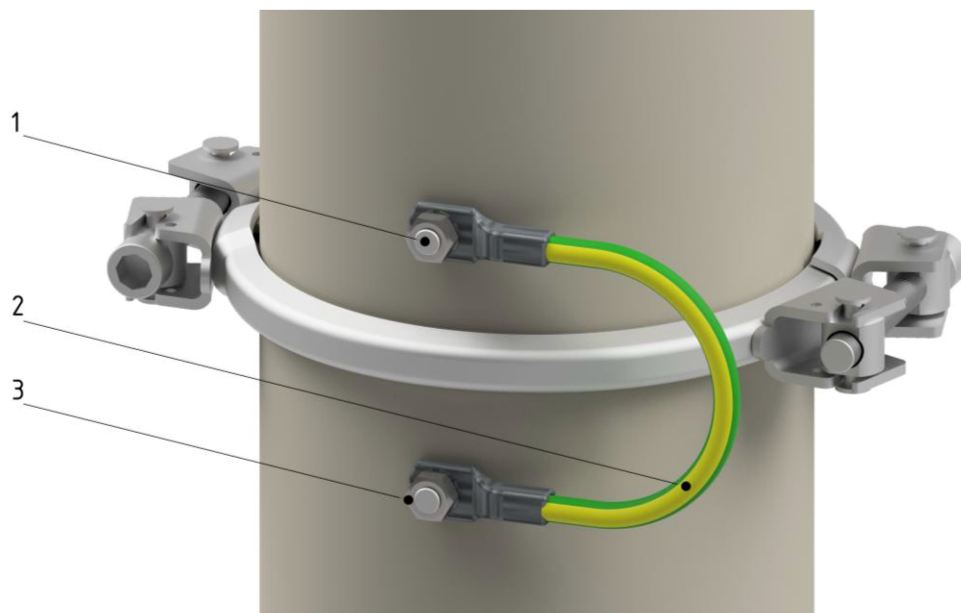

No.	Naming
1	Grounding bolt M6 x 10 mm
2	Ground cable (Copper, 16 mm <sup>2</sup> )
3	Tooth lock washer & Hexagonal Nut M6

### 7.3 Avoidance of ignition sources

For use in potentially explosive atmospheres, it must be ensured that no additional ignition sources can arise from static electricity or from impermissible heating such as continuous operation or too fast cycles.

Metallic surfaces can become charged and lead to sparking. Appropriate grounding must be ensured. Hot surfaces can cause an explosion. The maximum permissible surface temperature (130°C, see device marking) must not be exceeded. The maximum switching frequency of 100 switches/hour must not be exceeded. The speed of the moving components must not exceed 1m / sec.

The entry of metallic foreign bodies or smouldering nests must be avoided. Maintenance and cleaning plans must be drawn up and adhered to. The maintenance plan listed here in the chapter "Maintenance and inspection" (*see p.39, 9.1 Maintenance plan*) contains only the minimum requirements.

ATEX gates consist of equipment that is declared and labelled in accordance with Directive 2014/34/EU and simple non-electrical equipment without its own potential ignition source, which does not fall within the scope of Directive 2014/34/EU. An ignition hazard assessment has shown that assembling these devices into the assembly does not create any additional ignition hazard.

The assembly can be used in Zone 22 (dust). As an incomplete machine, it does not receive CE marking.

Care must be taken to ensure proper installation: The connections and pipelines must be connected in such a way that no dust can escape from the pipeline or the gate to the outside, so that no ignitable atmosphere can form.

## 8 Operational disruptions

If you need the help of our customer service or technical advice, we ask for the following information:

- The order confirmation number you received from us
- Gate serial number
- Type and extent of the disruption
- Time and circumstances of the disruption
- Suspected cause

Disruption	Possible cause(s)	Action(s)
<b>Slider plate cannot be moved</b>	Product adhesion to the slider plate*	Disassemble and clean the gate
	No electrical voltage	Check the power supply
	Operating pressure interrupted or insufficient	Check operating pressure
	Solenoid valve defective	Replace the solenoid valve
	Drive blocked	Check the drive and mechanics and release the blockage, replace the drive if necessary
<b>Low flow rate</b>	Product column clogged in the gate or pipeline	Locate and clear blockage
<b>Leakage of the gates</b>	Incorrect mounting position	Correct the mounting position
	Product deposition on the sealing surfaces	Disassemble and clean the gate
	Seals defective or worn	Replace seals



### NOTE

Due to high humidity or condensation in the system, the product can adhere to the slider plate and greatly affect the mobility of the slider plate.

## 9 Maintenance and inspection

### 9.1 Maintenance plan

The service life of the gate can be affected by the following maintenance intervals*:	
Every 1000 machine hours, at least quarterly	<ul style="list-style-type: none"> <li>▪ Visual inspection of seals for damage, replace damaged parts</li> <li>▪ Check the limit switches, adjust them if necessary</li> </ul>
Depending on operating conditions, no later than once a year	<ul style="list-style-type: none"> <li>▪ Check treads for damage / wear, replace damaged parts</li> <li>▪ Check the slider plate for damage / wear, replace damaged parts</li> </ul>
Depending on external influences and the characteristics of the conveying product	<ul style="list-style-type: none"> <li>▪ Check the inside of the case for impurities, clean if necessary</li> <li>▪ Check product-carrying parts for wear, replace if necessary</li> <li>▪ If necessary, repair or renew surface and corrosion protection paint</li> <li>▪ If necessary, adjust the time intervals for the replacement of treads and seals</li> </ul>



#### NOTE

The exact time intervals for inspection and maintenance must be determined by the manufacturer of the complete machine or by the plant operator.

### 9.2 Inspection requirements

For all inspection and maintenance work, observe the safety instructions ([see p.10, 2.3 General safety instructions](#)).

## 9.3 Replacement of spare parts

For safety reasons, only use original spare parts and accessories authorized by the manufacturer for the replacement of wear parts.

The use of other parts may result in personal injury and property damage, as well as loss of warranty claims.



### NOTE

- Spare part article numbers can be found in the technical data sheets.
- For the replacement of spare parts, the gate must be removed from the pipeline.

### 9.3.1 Replacement of the seal for pipe gates

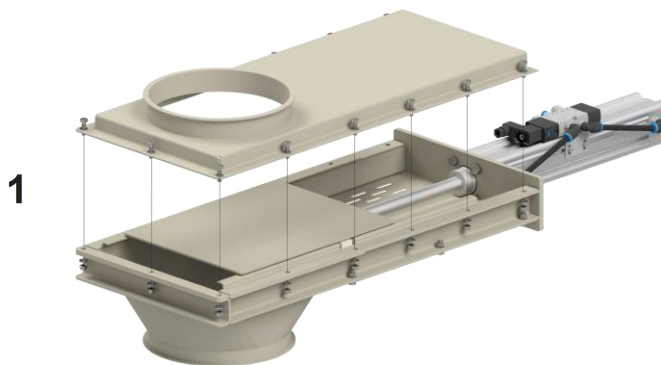

Loosen the screw connection between the upper part and the U-frame. Remove the top.

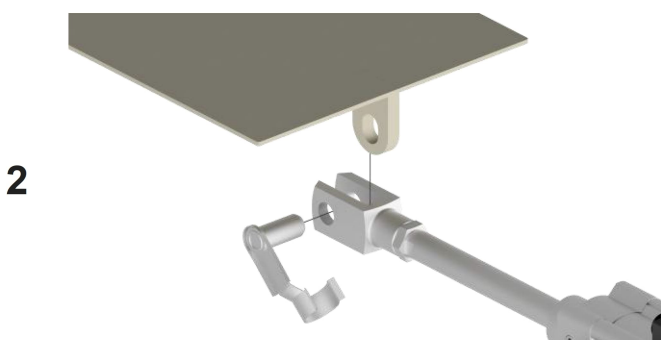

Loosen the connection between the cylinder clevis and the clevis holder on the slider plate. Set the slider plate aside.



Remove the lower sealing strip from the U-rail on the square flange.

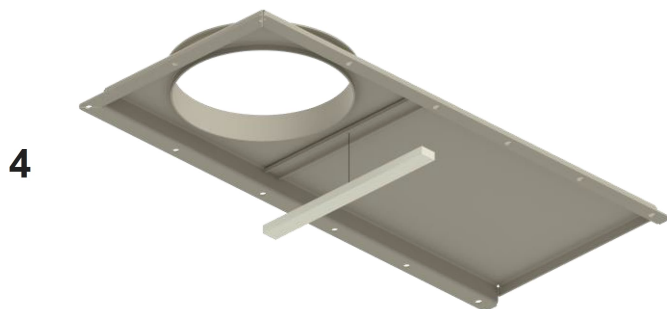

Remove the top sealing strip from the U-rail on the top.



The replacement seal is supplied by the metre and must be cut to size. It is possible that the seal to be replaced can be used to determine the length.

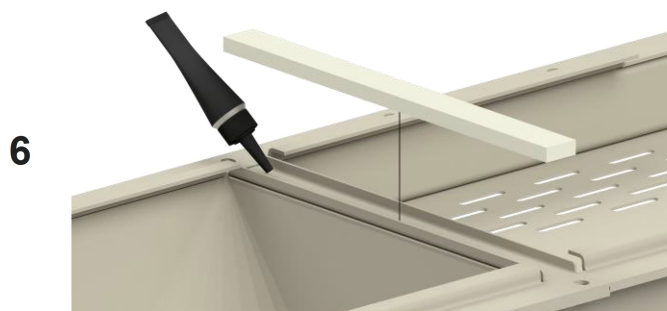

Clean the sealing surface in the lower U-rail and glue the seal in place. The adhesive must cure completely after installation.

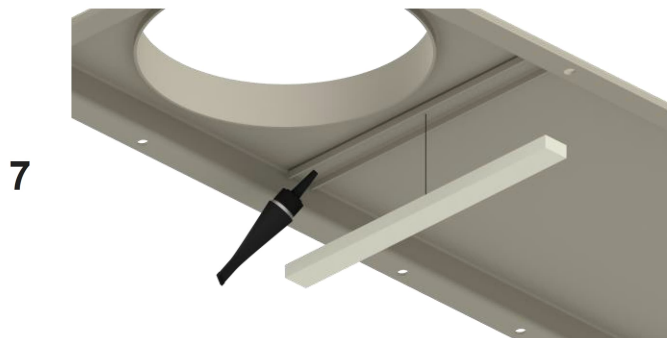

Clean the sealing surface in the upper U-rail and glue the seal in place. The adhesive must cure completely after installation.

### 9.3.2 Replacement of the seal for outlet gates

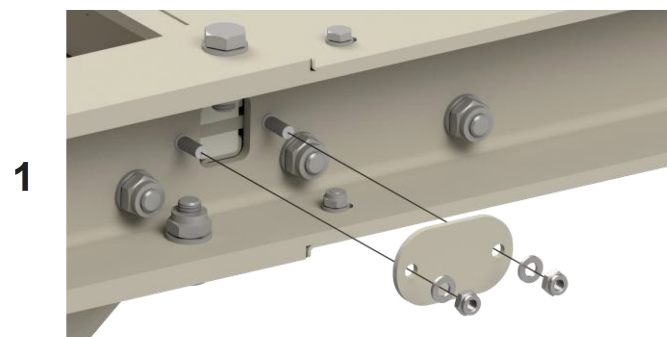

Loosen the hexagonal nuts of the control opening in the side U-frame to detect possible seal wear.

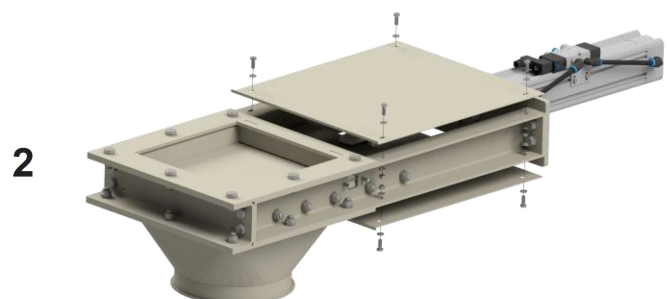

Loosen the screw connection of the upper and lower protective cover and remove them.

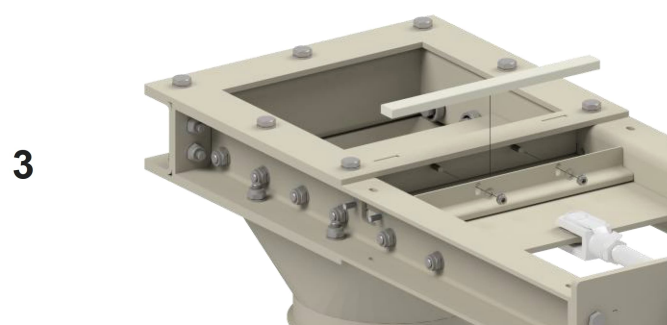

Loosen the screw connection from the sealing plate and pull it out.

The same type of connection is located on the bottom.



The replacement seal is supplied by the metre and must be cut to size. It is possible that the seal to be replaced can be used to determine the length.



Clean the sealing surface on the sealing plate and glue the seal in place. The adhesive must cure completely after installation.



Place the sealing plate over the threaded bolts, press it onto the slider plate and screw it in place with the hex nuts.

### 9.3.3 Replacement of a pneumatic lifting cylinder

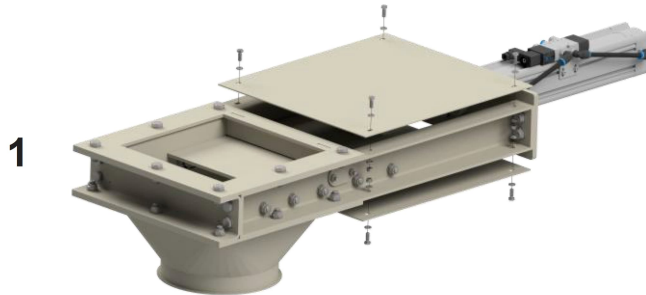

Loosen the screw connection of the upper and lower protective cover and remove them.

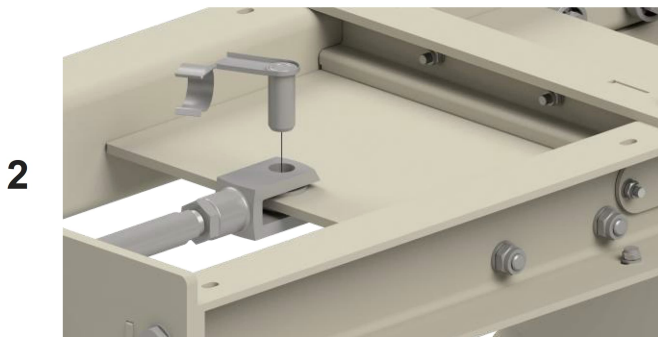

Loosen the connection between the slider plate and the clevis.

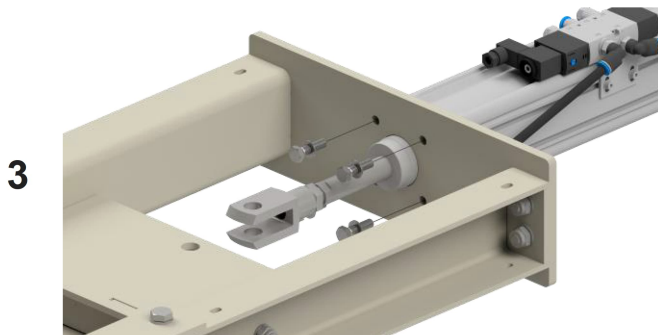

Loosen the screw connection of the lifting cylinder and the drive mount. The lifting cylinder can then be removed.



#### NOTE

- To install the new drive, carry out all steps in reverse order.
- The procedure for adjusting the end position can be found in the manufacturer's documentation.

### 9.3.4 Replacement of an electric linear actuator

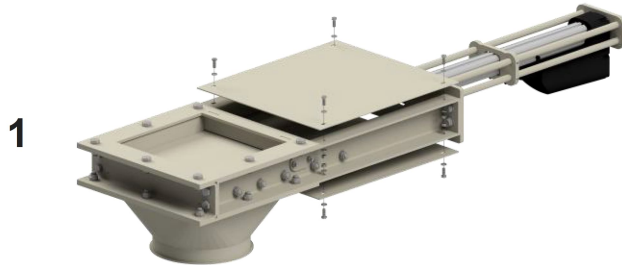

Loosen the screw connection of the upper and lower protective cover and remove them.

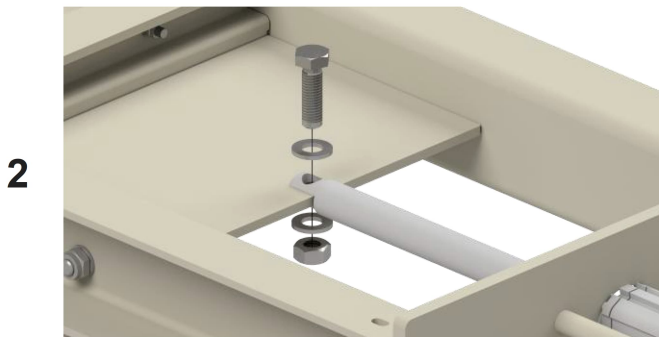

Loosen the connection between the slider plate and the clevis.

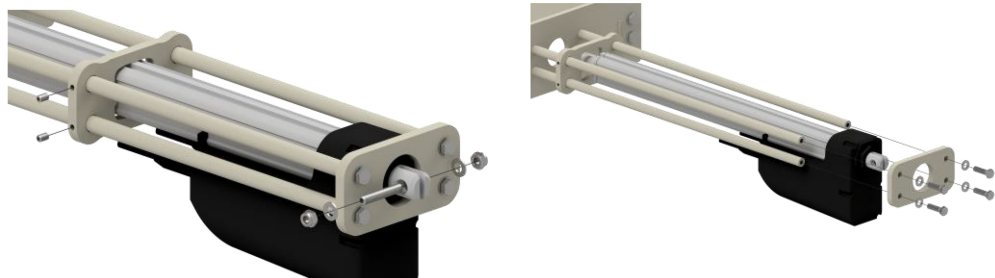

#### NOTE

- To install the new drive, carry out all steps in reverse order.
- The procedure for adjusting the end position can be found in the manufacturer's documentation.

## 9.4 Cleaning instructions

Clean the gate as specified in the maintenance plan (*see p.39, 9.1 Maintenance plan*).

The cleaning agents to be used and the cleaning procedures to be applied must be specified by the manufacturer of the complete machine or by the plant operator

## 10 Disassembly and disposal

### 10.1 Disassembly



#### WARNING

When disassembling, observe the safety instructions (*see p. 10, 2.3 General safety instructions*)!

We recommend disassembling our products into as many parts as possible, if it is safe to do so. Disassembly from the pipeline is carried out in reverse order, as in the procedures described in chapter 5 (*see p. 28, 5 Assembly*). When disassembling the drive, observe the relevant instructions provided by the drive manufacturer.

### 10.2 Disposal

NORO products can be disposed of by classifying them into different waste materials for reuse or incineration. If possible, recycle the individual waste materials when disposing of them. When disposing of the drive, observe the disposal instructions provided by the drive manufacturer. Please observe the country-specific disposal regulations.



#### NOTE

The illustrations are for illustrative purposes only. The product supplied may differ from the illustrations in terms of shape, colour and features. In the event of any discrepancies, please refer to the technical data in the acceptance report and the technical data sheets attached.